

## 21000 Series FLOW STRAIGHTENERS

# 520-3000



PEM 21000 Series custom made FLOW STRAIGHTENERS, are similar in design to modified 'Zanker' type double action flow straighteners and relate to the flow requirements & PEM Angular Spray Design Calculations as published in PEM catalogues.

All PEM spray design calculations are based upon linear, laminar and/or most of all, non-turbulent and/or twisting flow of water into the spray jet having minimum directional adjustment.

Where turbulence and/or twisting flow is present and better performance is desired, the use of flow straightening devices in the pipe riser to the jet can show dramatic sprayheight (distance) improvements.

For maximum spray performances and/or for use with silted water: Use custom made spray jets with flanged pipe connection and steel orifice sleeve.

PEM 21000 Series Flow Straighteners require orifice & flow sized pump suction strainers, see PEM Catalog Design Data for suction strainer sizing. Never use in line basket strainers in the pump suction except as protection for pump.

**Suggested Suction Strainer sizes in red in table for maximum flows.**

For more economic solutions or applications with lesser turbulence without water swirls see: **PEM 23000 Series Flow Straightening Flanges**

For smaller size Flow Straighteners see: **PEM 01050 Series**

PEM Serial	21025 520-3025	21030 520-3030	21040 520-3040	21060 520-3060	21080 520-3080	21110 520-3100	21120 520-3120
With order state: Inside pipe diam. & ASA or BSP flat Flange							
PIPE SIZE	2-1/2"	3"	4"	6"	8"	10"	12"
O.D. of Flange	127mm 5.000"	136mm 5.375"	175mm 6.900"	229mm 9.000"	280mm 11.000"	340mm 13.375"	411mm 16.187"
Thickness of Flange	10mm 0.394"	10mm 0.394"	10mm 0.394"	10mm 0.394"	10mm 0.394"	10mm 0.394"	10mm 0.394"
Length of Unit in pipe	317mm 12.5"	381mm 15"	508mm 20"	762mm 30"	1016mm 40"	1270mm 50"	1524mm 60"
Fit into pipe O.D. of Unit	60mm 2.362"	74mm 2.913"	99mm 3.898"	150mm 5.905"	198mm 7.795"	251mm 9.882"	302mm 11.890"
# of Tubes	36	41	42	53	50	56	58
I.D. of Tubes	4.826mm 0.190"	6.477mm 0.255"	9.321mm 0.367"	14.097mm 0.555"	20.447mm 0.805"	24.892mm 0.980"	29.972m 1.180"
Suct.Str. Orifice Size	3.175mm 0.125"	4.826mm 0.187"	6.000mm 0.250"	9.525mm 0.375"	10.000mm 0.393"	12.700mm 0.500"	15875mm 0.625"
Suct.Str.Type PEM 7280/90	'C' <b>7299</b>	'B' <b>7294</b>	'B' <b>7298</b>	'A' <b>7297</b>	'A' <b>Multiple 7297</b>	'A' <b>Multiple 7297</b>	'A' <b>Multiple 7297</b>
Flow: GPM = USGPM  Flow Straighteners are made of 304 Stainless steel. Flow Straighteners are inserted into pipe between flat companion flanges with suitable size flange ring gaskets (2)	Flow Press. Loss	Flow Press. Loss	Flow Press. Loss	Flow Press. Loss	Flow Press. Loss	Flow Press. Loss	Flow Press. Loss
	GPM Feet	GPM Feet	GPM Feet	GPM Feet	GPM Feet	GPM Feet	GPM Feet
	50 0.207	50 0.188	150 0.604	400 0.951	500 0.720	800 0.980	1000 0.930
	60 0.272	60 0.270	200 1.075	500 1.488	600 1.040	1000 1.520	1500 1.980
	75 0.383	75 0.423	250 1.680	600 2.140	800 1.860	1200 2.190	2000 3.540
	<b>100 0.612</b>	<b>100 0.754</b>	<b>300 2.420</b>	<b>800 3.811</b>	<b>1000 2.900</b>	<b>1500 3.340</b>	<b>2500 5.540</b>
	<b>150 1.080</b>	<b>150 1.527</b>	<b>350 3.290</b>	<b>900 4.890</b>	<b>1200 4.190</b>	<b>2000 5.940</b>	<b>3000 9.390</b>
		<b>200 2.610</b>	<b>400 4.480</b>	<b>1000 6.650</b>	<b>1600 7.450</b>	<b>2500 9.010</b>	<b>3500 10.870</b>
	L/min m.	L/min m.	L/min m.	L/min m.	L/min m.	L/min m.	L/min m.
	189.0 0.063	189.0 0.057	567.78 0.184	1513.8 0.289	1892.4 0.219	2271.0 0.298	3785.4 0.283
226.8 0.083	226.8 0.082	757.2 0.326	1892.4 0.453	2271.0 0.317	3028.2 0.463	5677.8 0.603	
283.8 0.116	283.8 0.128	946.2 0.512	2271.0 0.652	3028.2 0.566	3785.4 0.667	7580.8 1.070	
<b>378.0 0.186</b>	<b>378.0 0.229</b>	<b>1135.2 0.737</b>	<b>3028.2 1.161</b>	<b>3785.4 0.883</b>	<b>5677.8 1.018</b>	<b>9463.2 1.680</b>	
<b>567.6 0.329</b>	<b>567.6 0.465</b>	<b>1324.8 1.002</b>	<b>3331.2 1.490</b>	<b>4542.0 1.277</b>	<b>7566.0 1.810</b>	<b>11356.2 2.860</b>	
	<b>756.0 0.795</b>	<b>1434.0 1.365</b>	<b>3785.4 2.026</b>	<b>6056.4 2.270</b>	<b>9463.2 2.740</b>	<b>13249.2 3.310</b>	

# PEM



## 21000 Series FLOW STRAIGHTENERS

# 520-3000



Comparison of PEM 874 with 4" identical ABS pipe riser of design length on 4", 90° Elbow Fitting Sprayheight appr. 17 feet ( 5.1m) , 1.5" Orifice, 178 GPM (674 L/min) x 22.8 Ft (6.95m) Head



PEM 874B to 5.1m - 17 Ft ,  
on 4" Elbow, No Flow Straightener



PEM 874B to 5.1m - 17 Ft, on 4" Elbow  
with PEM 21040 Flow Straightener

### Flow / Pressure Loss Formula for PEM 21000

$$h = V^2 (fL/D+k) / 2g$$

- f*=friction factor(Darcy-Wisbach formula)
- L*=pipe length , ft
- D*=inside pipe diameter
- g*=acceleration of gravity, 32.17 ft/s<sup>2</sup>
- k*=0.45
- V*=velocity of the stream , ft/s

### FLOW STRAIGHTENER POSITIONING

- '01' Flange of Flow Straightener
- '02' Pipe ( Inside Diameter to be specified )
- '03' (2) Flat Face Pipe Flanges (ASA or BSP)
- '04' (2) Flange Gaskets

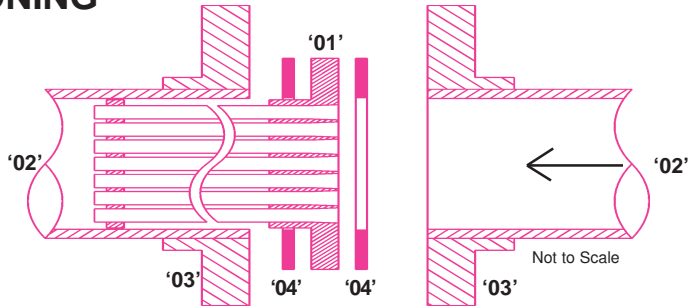

### NOZZLE / JET RISER PIPE WITH FLOW STRAIGHTENER ON ELBOW

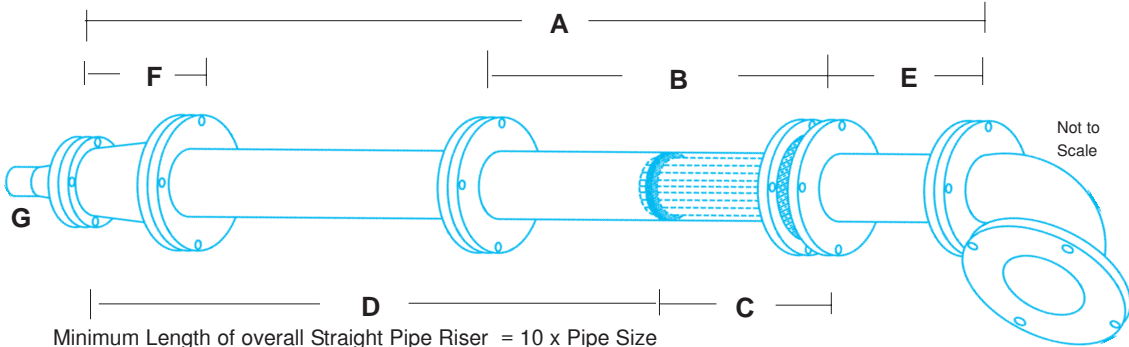

- A** = Minimum Length of overall Straight Pipe Riser = 10 x Pipe Size
- B** = Center Part of Straight Pipe Riser, longer than Flow Straightener to permit insertion of same
- C** = Length of Flow Straightener Unit in pipe , see page one.
- D** = Length of Straight Pipe Riser between end of flow straightener and nozzle = 3 to 10 times pipe size
- E** = Length of straight pipe between inflow elbow and flow straightener = 1 to 2 times pipe size
- F** = Nozzle or Jet, either with threaded or flanged pipe connection or flanged tapered pipe reducer from riser pipe size to nozzle pipe size terminating in threaded companion flange and close pipe nipple or plain pipe flange, depending on nozzle or jet pipe connection.
- G** = Nozzle or Jet, either with threaded or flanged pipe connection mounted on tapered reducer fitting.
- H** = Flanged inflow pipe elbow.

PEM 21000 Series custom made FLOW STRAIGHTENERS, are similar in design to modified 'Zanker' type double action flow straighteners and relate to the flow requirements & PEM Angular Spray Design Calculations as published in PEM catalogues.

